

Experimental and numerical study, under LTC conditions, of ammonia ignition delay with and without hydrogen addition

Pochet, Maxime; Dias, Véronique; Moreau, Bruno; Foucher, Fabrice; Jeanmart, Hervé; Contino, Francesco

Published in:
Proceedings of the Combustion Institute

DOI:
[10.1016/j.proci.2018.05.138](https://doi.org/10.1016/j.proci.2018.05.138)

Publication date:
2019

Document Version:
Accepted author manuscript

[Link to publication](#)

Citation for published version (APA):

Pochet, M., Dias, V., Moreau, B., Foucher, F., Jeanmart, H., & Contino, F. (2019). Experimental and numerical study, under LTC conditions, of ammonia ignition delay with and without hydrogen addition. *Proceedings of the Combustion Institute*, 37(1), 621-629. <https://doi.org/10.1016/j.proci.2018.05.138>

Copyright

No part of this publication may be reproduced or transmitted in any form, without the prior written permission of the author(s) or other rights holders to whom publication rights have been transferred, unless permitted by a license attached to the publication (a Creative Commons license or other), or unless exceptions to copyright law apply.

Take down policy

If you believe that this document infringes your copyright or other rights, please contact openaccess@vub.be, with details of the nature of the infringement. We will investigate the claim and if justified, we will take the appropriate steps.

Experimental and numerical study, under LTC conditions, of ammonia ignition delay with and without hydrogen addition

Maxime Pochet^{a,b,c,*}, Véronique Dias^a, Bruno Moreau^d, Fabrice Foucher^d, Hervé Jeanmart^a, Francesco Contino^{b,c}

^a*iMMC, Université catholique de Louvain, Louvain-la-Neuve, Belgium*

^b*Department of Mechanical Engineering, Vrije Universiteit Brussel, Brussels, Belgium*

^c*BURN Joint Research Group, Vrije Universiteit Brussel & Université Libre de Bruxelles, Brussels, Belgium*

^d*Laboratoire PRISME, Université d'Orléans, Orléans, France*

Abstract

For long-term storage, part of the excess renewable energy can be stored into various fuels, among which ammonia and hydrogen show a high potential. To improve the power-to-fuel-to-power overall efficiency and reduce NO_x emissions, the intrinsic properties of Low Temperature Combustion (LTC) engines could be used to convert these carbon-free fuels back into electricity and heat. Yet, ignition delay times for ammonia are not available at relevant LTC conditions. This lack of fundamental kinetic knowledge leads to uncertain ignition delay predictions by the existing ammonia kinetic mechanisms and prevents from determining optimal LTC running conditions. Using a Rapid Compression Machine (RCM), we have studied the ignition delay of ammonia with hydrogen addition (0%, 10%, and 25%vol.) under LTC conditions: low equivalence ratios (0.2, 0.35, 0.5), high pressures (43 bar and 65 bar) and low temperatures (1000 K - 1100 K). This paper presents the comparison of the experimental data with simulation results obtained with five kinetic mechanisms found in the literature. It then provides a sensitivity analysis to highlight the most influencing reactions on the ignition of the ammonia-hydrogen blends. The obtained range of ignition delays for pure ammonia and for the ammonia-hydrogen blends prove their suitability for LTC engines. Still the hydrogen addition must be greater than 10%vol. to produce a significant promotion of the ignition delay. The two best performing mechanisms still predict too long ignition delays for pure ammonia, while the delays become too short for ammonia-hydrogen blends. A third mechanism captures correctly the relative influence of hydrogen addition, but is globally over-reactive. Through a sensitivity analysis, H₂NO has been identified as the main cause for the under-reactive pure ammonia kinetics and N₂H_x has been identified as the main cause for globally over-reactive ammonia-hydrogen mechanisms.

Keywords:

Ammonia, Rapid Compression Machine, ignition delay, Low Temperature Combustion, kinetic mechanisms

Corresponding author's contact informations:

Address: 2 Place du Levant,
1348 Louvain-La-Neuve, Belgium
Tel: +32 10 47 22 20
Email: max.pochet@uclouvain.be

Internal combustion engines

Total length of paper: 8.0 pages excluding 1.0 page appendix (using method 2 for Latex users from the 2017 additional author instructions)

Colloquium describing the research topic:

Gas-phase reaction kinetics

Supplementary material: Reference [20] available in the supplementary materials as it is under review in Combustion and Flame.

Secondary colloquium in connexion with the research topic:

*Corresponding author

Email address: max.pochet@uclouvain.be (Maxime Pochet)

1. Introduction

Worldwide interest is growing for ammonia as an alternative fuel obtained as a by-product of renewable energy systems. Indeed, massive penetration of renewables will lead to electricity excess that could be advantageously stored as a fuel through Power-to-Fuel (P2F). Being carbon-free, easily produced from hydrogen and nitrogen (extracted from the air), ammonia is easily stored and transported (liquid under 9 bar of pressure), and shows a real potential in the frame of new energy systems [1].

In the search for higher efficiencies and lower emissions, the use of a Low Temperature Combustion (LTC) mode for ammonia combustion has been suggested and investigated first by Van Blarigan with a 40:1 compression ratio free piston Homogeneous-Charge Compression-Ignition (HCCI) engine [2] and more recently by the authors with a 15:1 compression ratio HCCI engine [3, 4]. These studies put forward the high resistance of ammonia to auto-ignition. It needs, therefore, to be promoted by another fuel (e.g. hydrogen) or to be brought to a high temperature by a high compression ratio or a high inlet temperature. Increasing the compression ratio increases the thermodynamic efficiency but increases the friction and heat losses as well. However a high inlet temperature affects the power density and heat losses and therefore decreases the brake efficiency. Moreover hydrogen is known to be prone to ringing at the high compression ratios required by the ammonia LTC compression-ignition mode, but ammonia is known to decrease the ringing potential of a mixture [4, 5]. Therefore a trade-off is to be made for the ammonia-hydrogen engine design but the knowledge on ammonia use under LTC conditions is too low: the conditions under which ammonia could and should be used alone in an LTC engine and how its reactivity and ringing behaviour would evolve with small fractions of added hydrogen are to be studied.

Many mechanisms have been built to represent ammonia oxidation kinetics. The two main applications and origins of development for these mechanisms are the DeNO_x process and the combustion in Spark Ignition (SI) engine. However it is legitimate to question their suitability/representativeness for ammonia ignition delay under LTC mode (mid-range temperature) and with hydrogen addition.

Most studies on ammonia were performed for the nitrogen/(NO_x) chemistry or the DeNO_x process [6–12], including solid fuel combustion leading to ammonia and other nitrogen species formation [13, 14]. These studies, although realised at a range of temperatures in-

cluding those of LTC (900-1400 K), were performed with small traces of ammonia and at low pressure. Regarding ammonia oxidation in flames, several studies have been performed, from the reaction rate investigations to the global mechanism behaviour, under close to stoichiometric conditions and at high temperatures (> 1500 K) [8, 10, 15, 16]. It is only recently that two studies on the ignition delay of ammonia at high pressures and under lean conditions have been performed. Mathieu and Petersen measured ammonia ignition delays in a shock tube up to 30 bar, with an equivalence ratio of 0.5, but under diluted conditions and from 1560 K to 2455 K [17]. Song et al. measured ammonia oxidation in a laminar flow reactor at up to 100 bar, at an equivalence ratio of 0.2, but between 450 K and 925 K [18]. However both studies were performed without hydrogen addition and the temperature range of interest for LTC conditions has not been covered (1000 K - 1100 K).

The present study uses a Rapid Compression Machine (RCM) to fill the gap in ammonia ignition delay data, with and without hydrogen addition, at representative conditions for the LTC mode: low temperatures (1000 K - 1100 K), without dilution, at lean conditions (equivalence ratios, ϕ , of 0.2, 0.35, and 0.5), and at high pressures (43.4 bar and 65.5 bar). The objective of this paper is to answer the following questions: (1) how is ammonia ignition delay evolving in LTC conditions? and (2) how does the ignition delay evolve with hydrogen addition? Moreover the five most-developed ammonia mechanisms found in the literature are compared against the experimental results to assess their performance in LTC conditions and, finally, a sensitivity analysis is performed to highlight the most influencing reactions that might induce the observed ignition delay estimation errors.

2. Experimental and numerical methodology

This section describes both the experimental and numerical tools and methodology used to obtain ignition delay results. After presenting the studied mixtures and the wall passivation technique, it provides the analysis of uncertainty on the ignition delay measurements.

2.1. Experimental set-up

The experimental set-up used in this study is the single piston RCM of the Université d'Orléans, PRISME laboratory, described in Table 1 and Figure 1. The geometry of this machine (crevices and compression technique) is based on the RCM at the Argonne National

Laboratory [19]. The high crevice volume allows a strong absorption of the boundary layer to minimize the formation of a roll-up vortex during the compression. Following the crevice validation methodology of Bourgeois et al. [20], the crevice volume is 13% below the conservative volume that guarantees the absence of a vortex. In the case where small vortices would develop near the crevice region, given that neither ammonia nor hydrogen has a negative temperature coefficient region, there would be no effect on the ignition delay as the auto-ignition onset would still happen in the core region.

Table 1: RCM main characteristics

Bore - Stroke	50 - 300 mm
Compression time	35 ms
Time $p_{\max}/2$ to p_{\max} (t_{50})	4 ms
Max. piston velocity	11.5 m/s
Piston acceleration	1500 m/s ²
Acceleration time	15 ms
Piston deceleration	4500 m/s ²
Deceleration time	5 ms
Crevice volume	4.82 cm ³
Compression ratio	24.34:1
Intake temperature	20-110 °C

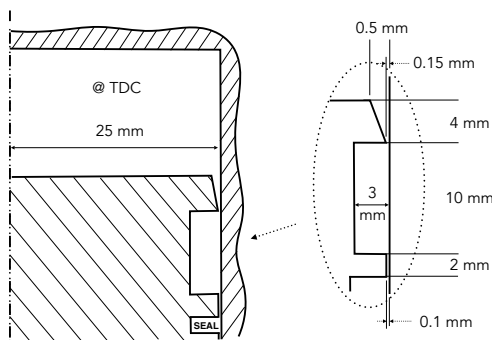

Figure 1: Design of the RCM at the Université d'Orléans.

Several sensors affect the measurement of the ignition delay, τ , defined as the time between the end of the compression (i.e. maximum compression pressure) and the combustion Maximum Pressure Rise Rate (MPRR):

$$\tau = t_{MPRR} - t_{Pc} \quad (1)$$

The intake pressure was controlled by a KELLER PAA-33X/80794 piezoresistive transducer that compensates for temperature dependencies and non-linearities. For a scale of 0 to 5 bar, its accuracy is ± 0.2 mbar and the precision is 0.1 mbar. Regarding the in-cylinder pressure acquisition, a piezoresistive AVL

QH32C transducer having a linearity of $\pm 0.2\%$ and an accuracy of $\pm 1\%$ was used. The charge amplifier, a KISTLER 5011, induces an error smaller than 1% of the current received. The pressure signal has a sampling frequency of 20 MHz and is filtered through a normalized Butterworth cut-off frequency of 0.03. The intake temperature measurement is done by a type K thermocouple having an accuracy of ± 1 K. Finally the mass flow controller used is a BROOKS Cori-Flow M13V10I and has an accuracy of $\pm 1\%$ on the flow rate.

2.2. RCM model and kinetic mechanisms

With well designed RCM crevices, the temperature and chemical composition can be considered uniform in the core zone, outside of the boundary layer. Therefore a 0-dimensional model can be used to represent the thermodynamic state in this core zone (i.e. the hottest region, relevant for the chemical kinetics). The widely-used model of the *effective adiabatic core volume* has been implemented to capture this core zone [19, 21]. Based on an experimental non-reactive pressure curve, the *effective volume* of the RCM combustion chamber is the volume that will give, for an isentropic compression, the exact same pressure as the experimental non-reactive one. Therefore the heat losses are implicitly taken into account by the *effective volume* that is slightly higher than the geometric one during compression, and that expands during the post-compression period. This *effective volume* allows as well to take machine-related effects and imperfections into account in the simulations. Finally, to be representative of the combustion cases, the *effective volume* is based on non-reactive pressures obtained by replacing the oxygen of the various combustion cases with nitrogen.

This thermodynamic model is used together with five ammonia-hydrogen kinetic mechanisms. The first mechanism is the one of Konnov and De Ruyck (**KD**) [15]. It is a H/N/O model tested for ammonia and hydrogen oxidation, ignition and flame structure at high temperatures [16].

The second mechanism, by Zhang et al. (**ZH**) [22], is an hydrogen/syngas/ NO_x model including the ammonia sub-mechanism from Mathieu and Petersen [17] and the NNH sub-mechanism of Klippenstein et al. [12]. The ammonia sub-mechanism is based on lean ammonia shock tube ignition delays at medium to high pressures (1.4, 11, and 30 bar) and high temperatures (1560 K - 2455 K) [17]. The NNH sub-mechanism has been built for the DeNO_x process and validated at medium temperatures (1000 K - 1500 K) [12].

The third mechanism, also based on the NNH sub-mechanism of Klippenstein et al., is the mechanism of

Song et al. (SO) and is modified according to their high pressure (30 and 100 bar) and low temperatures (450-925 K) ignition delays for lean to stoichiometric ammonia mixtures [18].

The fourth mechanism is the one of Dagaut-Kéromnès (DK). It is based on the Dagaut and Nicolle work [11] on the reduction of NO_x by ammonia under lean conditions and on the H_2 -CO work of Kéromnès et al. [23] on hydrogen ignition delay at elevated pressures, both performed in the LTC temperature range. The DK mechanism has been validated by Li et al. [24] for stoichiometric ammonia-hydrogen flames and for the Mathieu and Petersen pure ammonia ignition delay data.

The final mechanism from Nakamura et al. (NK) [25] is based on the Miller and Bowman DeNO_x mechanism [6], completed with: the H_2 - NH_x - NO_2 - N_2O chemistry of Mathieu and Petersen [17], the H_2 -CO chemistry of Kéromnès et al. [23], and the N_2H_x chemistry of Konnov and De Ruyck [15]. Nakamura et al. describe their mechanism as a "bridge between the Mathieu and Petersen mechanism at high temperatures and the [KD] mechanism at low temperatures" [25].

The five mechanisms (KD, ZH, SO, DK, NK) are used regardless of the in-cylinder pressure, hence considering the molecular reactions to happen by binary collisions, except for modelled third body reactions. The experimental in-cylinder maximum pressures are below 80 bar for the compression pressure of 43.4 bar and below 110 bar for the compression pressure of 65.5 bar.

2.3. Experimental conditions

To achieve different compression pressures and temperatures, the intake pressure is varied between 400 mbar and 1250 mbar, and the intake temperature between 60 °C and 110 °C. Moreover argon is used to replace part of the inert nitrogen to help achieving higher compression temperatures with moderate intake temperatures. The mixtures used during the experimental campaign are detailed in Table 2.

Ammonia adsorbs with time on stainless steel, which might decrease the actual equivalence ratio of the mixture between consecutive shots [17]. For that reason the liner of the RCM has been layered with chrome to minimize the contact with steel. Moreover the mixture reservoir (made out of stainless steel 304) was passivated following the procedure of Mathieu and Petersen [17]: reservoir filling with pure ammonia at a pressure of 133 mbar for 5 minutes followed by a complete vacuuming for 5 more minutes. To test the influence of passivation, the reservoir has been filled with mixture #1 a first time without, and a second time with prior passivation and

Table 2: Molar fractions of the different mixtures used

Mixture	1	2	3	4	5
$\text{NH}_3:\text{H}_2$ (%vol.)	100:0	100:0	90:10	75:25	100:0
ϕ	0.2	0.35	0.35	0.35	0.5
NH_3 (%)	5.31	8.93	8.29	7.25	12.29
H_2 (%)	-	-	0.92	2.42	-
O_2 (%)	19.89	19.13	19.07	18.98	18.43
N_2 (%)	74.80	61.15	60.96	60.66	55.43
Ar (%)	-	10.79	10.76	10.70	13.86

five consecutive shots have been made each time. For a Welch F test with a confidence level of 0.01, there was no statistical difference between the two samples mean ignition delay or a decay in ignition delay. Still the passivation was used for all experiments.

2.4. Uncertainty and repeatability of the machine

To characterise the repeatability and uncertainty of the machine, two sets of five measurements for both short and long ignition delays have been performed. For the five repeated points of mixture #1 with passivation and with intake pressure and temperature set at 1075 mbar and 89 °C, the mean ignition delay is 36.83 ms. The standard deviation is $s = 1.00$ ms. For an assumed normal distribution of the ignition delay population, the sample drawn follows a Student's t distribution and the uncertainty on ignition delay at a confidence level of 95% (U_{95}) is:

$$U_{95} = \pm t_{4 \text{ dof}}^{0.05/2} s = \pm 3.0 \text{ ms} ,$$

These five repeated conditions were obtained with a variability in compression pressure and temperature of ± 0.4 bar and ± 1.5 K, respectively.

For the same mixture at an intake pressure and temperature of 1100 mbar and 115 °C, the mean ignition delay is 8.63 ms. Following the same procedure, the uncertainty on the ignition delay with a confidence level of 95%, for a sample of five measurements, is $U_{95} = \pm 1.2$ ms. For this sample the variability in compression pressure and temperature was of ± 0.3 bar and ± 1.0 K, respectively.

3. Results and discussion

In this section experimental and numerical ammonia ignition delays are reported as a function of temperature, pressure, equivalence ratio, and hydrogen addition. Finally a sensitivity analysis is performed to improve the prediction of the best mechanisms.

3.1. Pure ammonia ignition delay: temperature and pressure dependences

Pure ammonia ignition delay as a function of the compression temperature is depicted in Figure 2. Given the obtained range of ignition delays (3 ms - 30 ms), these measurements show the suitability of pure ammonia use in a slightly pre-heated intake ($\sim 170^\circ\text{C}$, due to the absence of argon in a real situation) LTC engine with a compression ratio of 25:1. Regarding the mechanisms, SO and DK (both originating from DeNOx process study) capture ammonia ignition delays best, while KD is over-reactive (as observed by Mathieu and Petersen [17]) and ZH under-reactive. The two best performing mechanisms originate from the DeNOx process study (and therefore from mid-range temperatures). Finally NK is over-reactive as well and very similar to KD, although based on a DeNOx mechanism. This might be an evidence of the predominance of the N_2H_x chemistry for pure ammonia conditions.

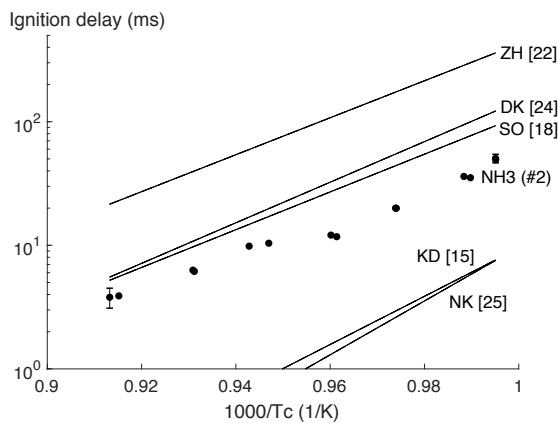

Figure 2: Experimental and numerical ammonia ignition delays as a function of the compression temperature, and for an equivalence ratio of 0.35 and a compression pressure of 65.5 bar (mixture #2). The obtained range of ignition delays (3 ms - 30 ms) shows the suitability of pure ammonia use in an LTC engine.

Figure 3 shows the influence of the pressure at the end of compression on ammonia auto-ignition. As the pressure increases, ammonia ignition delay experiences a marked decrease followed by a more gentle reduction for compression pressures above 55 bar. This highlights the interest of a high compression ratio or a boosted LTC engine operating with ammonia. Regarding the mechanisms, the error on the ignition delay estimation increases with the compression pressure for all the

mechanisms, except KD, stressing out the fact that they were not obtained for high pressure ammonia oxidation.

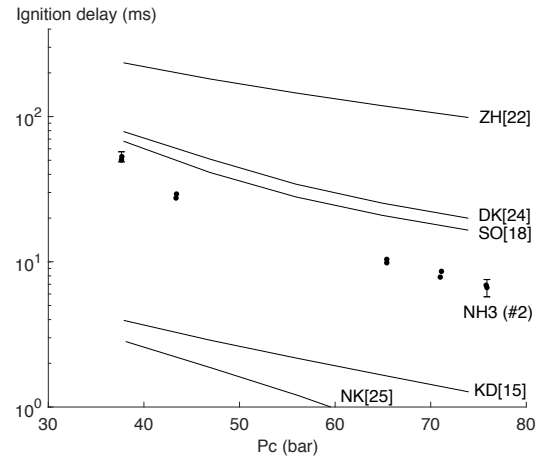

Figure 3: Experimental and numerical ammonia ignition delay as a function of the compression temperature, and for an equivalence ratio of 0.35 and with a fixed intake temperature of 353 K (mixture #2).

3.2. Influence of hydrogen addition on ammonia ignition delay

The evolution of the ammonia ignition delay with hydrogen addition is shown in Figure 4. The evolution of the ignition delay with the compression temperature is not observed to be influenced by the hydrogen fraction (i.e. the same variation in ignition delay is obtained for a given change in compression temperature). Moreover, the impact of hydrogen addition on the ignition delay seems to be highly dependent on the hydrogen concentration: a small quantity of hydrogen addition seems to have a limited influence on the ignition delay, but increasing the hydrogen fraction up to 25% induces a considerable reduction in the ignition delay. Therefore to promote ammonia under LTC conditions, and allow lower intake temperatures to be used, substantial amounts of hydrogen are required. Regarding the mechanisms at 10% vol. hydrogen, ZH and SO are now over-reactive, and DK is highly over-reactive. KD is so reactive that the modelled combustion happens entirely during the compression. Therefore this mechanism will no longer be used for the rest of this study. Contrary to KD, NK is only slightly over-reactive with some hydrogen content, meaning that the NH_3 sub-mechanism of Mathieu and Petersen that has been added to NK captures qualitatively well the hydrogen-ammonia interactions. Finally, the over-reactivity of the three best

mechanisms (SO, ZH, and NK) decreases substantially at 25%vol. of hydrogen content.

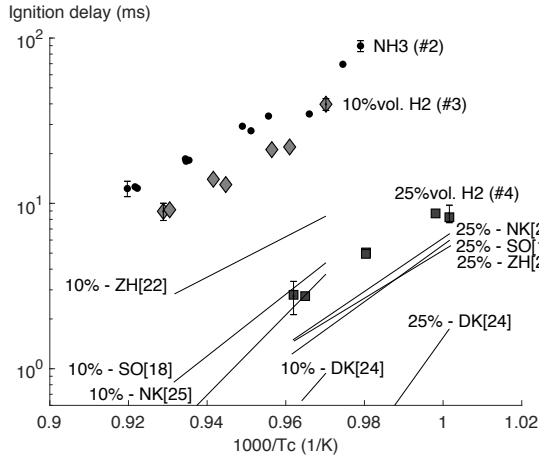

Figure 4: Experimental and numerical ammonia-hydrogen ignition delays at an equivalence ratio of 0.35 and a compression pressure of 43.4 bar (mixture #2,3,4).

To better grasp the influence of hydrogen addition, Figure 9 reports the evolution of the experimental and modelled ignition delays as a function of the hydrogen %vol. Results for NK, SO, and ZH mechanisms are plotted. For a blend of fuels, it is generally observed that the logarithm of the obtained ignition delay is linearly correlated to the molar fraction of the respective fuel ignition delays, as for the hydrogen-methane case [26]. As observed in Figure 9, the experimental results of the ammonia-hydrogen blend do not follow this empirical rule for the first few %vol. of hydrogen added, meaning that the radical pool created by the early hydrogen auto-ignition is not sufficient to trigger ammonia kinetics. Such behaviour is obtained, solely, by the NK mechanism, although globally over-reactive. The global over-reactivity of NK might be brought by the N_2H_x chemistry of KD. According to SO and ZH predictions, only a small fraction of hydrogen is required to induce a much earlier auto-ignition. This implies that either the pure ammonia chemistry under LTC conditions is not well captured or that the hydrogen-ammonia interactions are too strong, since the ammonia sub-mechanism is globally under-reactive. An in-depth sensitivity analysis is necessary to distinguish the base mechanism responsible for a correct ammonia reactivity and the base mechanism responsible for correct hydrogen-ammonia interactions.

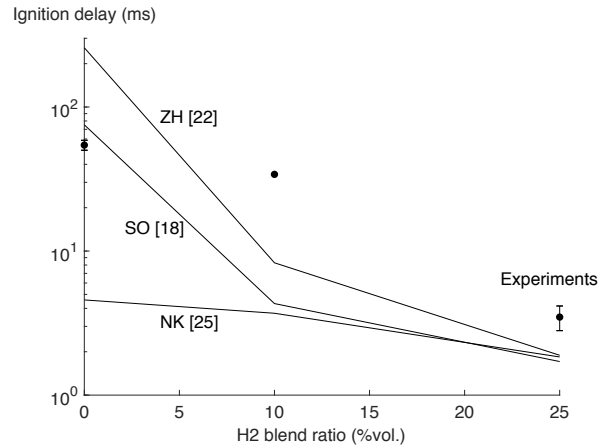

Figure 5: Ignition delay as a function of the hydrogen content %vol., at an equivalence ratio of 0.35, a compression temperature of 1031 K and a compression pressure of 43.4 bar (mixture #2,3,4).

3.3. Influence of the equivalence ratio on ammonia ignition delay

Figure 6 shows the evolution of the pure ammonia experimental ignition delay as a function of the equivalence ratio. There is a small dependence of the ignition delay on the equivalence ratio. However, for a given temperature, the variability of the ignition delay is close to the respective uncertainty regions. This result implies that a perturbation created by a small change in the equivalence ratio could easily be handled by an engine control system. Yet the reasons for a possible equivalence ratio leading to a higher ammonia reactivity under LTC conditions, and its variability with the temperature, is still an open question.

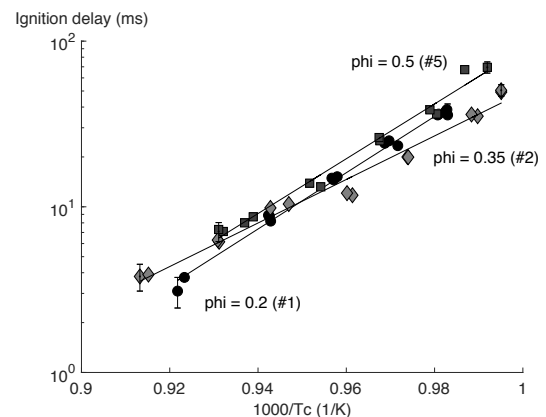

Figure 6: Experimental ammonia ignition delays, and their linear regressions, as a function of the equivalence ratio and at compression pressure of 65.5 bar.

3.4. Sensitivity analysis of the kinetic mechanisms: pure ammonia and ammonia hydrogen blends

Three mechanisms with different origins and reactivity will be used for the sensitivity analysis: ZH (under-reactive, based on ammonia oxidation at high temperature), SO (under-reactive, based on DeNOx at low temperature), and NK (over-reactive, based on ammonia oxidation at high temperature). The sensitivity analysis will be performed on the OH radical at its peak timing, as it has been shown to produce very similar results to a sensitivity analysis on the ignition delay [17]. The sensitivity analysis is done using the OpenSMOKE++ software [27, 28]. Reactions with a normalized sensitivity coefficient lower than 0.2 are discarded.

The first sensitivity analysis is performed for mixtures #2,3,4 (at 1075 K, 50 bar) and with the mechanisms ZH and SO to extract the reactions responsible for an under-reactivity with pure ammonia and an over-reactivity for ammonia-hydrogen blends. The raw results of the sensitivity analysis are reported in appendix. Out of the influencing reactions, the only ones that would promote the ignition delay of pure ammonia and reduce (or not influence) the reactivity of ammonia-hydrogen blends are the same for both mechanisms, see Table 3 and Table 4. Four of the highlighted reactions are common to both mechanisms and three of them are linked to the H₂NO chemistry. Therefore the H₂NO chemistry seems to play a significant role in the under-reactivity of pure ammonia and over-reactivity of hydrogen-ammonia auto-ignition. Moreover, the rate coefficients of these reactions are not well known: they have been established solely by estimations or *ab Initio* calculations. All these elements seem to pin the H₂NO chemistry as a potential direction for ammonia mechanism improvement under LTC conditions.

The second sensitivity analysis, still performed for mixtures #2,3,4 (at 1075 K, 50 bar), is done on the over-reactive NK mechanism, see the appendix for the raw results. Out of the influencing reactions on the ignition delay of pure ammonia, 7 are coming from the N₂H_x chemistry. Only 3 out of these 7 reactions are observed in the ZH and SO mechanisms, with different rate coefficients, but they do not appear in the influencing reactions. Therefore the pure ammonia over-reactivity of NK can be attributed mainly to the N₂H_x chemistry coming from the over-reactive KD mechanism.

The goal of this sensitivity analysis is to extract the reactions responsible for a generally over-reactive NK mechanism, without impacting the relative reactivity between the different blends that seems to fit the experimental results, see Figure 9. Therefore only the reactions influencing the three different blends, and having

Table 3: Details for the ZH reactions that could improve both ignition delay estimations for pure ammonia and ammonia-hydrogen blends.

#	Reactions	Ref.	Method
1	$\text{HO}_2 + \text{H}_2\text{NO} = \text{H}_2\text{O}_2 + \text{HNO}$	[29]	Estimation
2	$\text{H}_2\text{NO} + \text{NO}_2 = \text{HNO} + \text{HONO}$	[30]	Estimation
3	$\text{O}_2 + \text{NH}_2 = \text{O} + \text{H}_2\text{NO}$	[12]	<i>ab Initio</i>
4	$\text{HONO} + \text{NH}_2 = \text{NO}_2 + \text{NH}_3$	[31]	<i>ab Initio</i>

Table 4: Details for the SO reactions that could improve both ignition delay estimations for pure ammonia and ammonia-hydrogen blends.

#	Reactions	Ref.	Method
1	$\text{HO}_2 + \text{H}_2\text{NO} = \text{H}_2\text{O}_2 + \text{HNO}$	[29]	Estimation
2	$\text{H}_2\text{NO} + \text{NO}_2 = \text{HNO} + \text{HONO}$	[18]	Estimation
3	$\text{O}_2 + \text{NH}_2 = \text{O} + \text{H}_2\text{NO}$	[12]	<i>ab Initio</i>
5	$\text{HNOH} + \text{NH}_2 = \text{H}_2\text{O} + \text{H}_2\text{NN}$	[29]	Estimation
4	$\text{HONO} + \text{NH}_2 = \text{NO}_2 + \text{NH}_3$	[32]	<i>ab Initio</i>

higher sensitivity coefficients for pure ammonia than for the hydrogen containing blends, are to be considered for the mechanism improvement under LTC conditions, see Table 5. Still, reactions #6, 9, and 10 must be discarded since their rate coefficients are identical to those of the SO and ZH mechanisms. Reactions #12 and 13 are interesting in the sense that they present different rate coefficients than the ones used in all the other mechanisms, hence a source of over-reactivity. Finally, reactions #7, 8, and 11 belong to the N₂H_x chemistry and are potential candidates for improvement. Indeed, reactions #7 and 11 do not appear in the other mechanisms, and reaction #8 has different rate coefficients than in the other mechanisms. Even though obtained experimentally, the conditions were not representative for LTC mode: atmospheric temperature and pressure for reaction #7 and rich and atmospheric pressure, but medium temperatures, for reactions #8 and 11. This led Nakamura et al. to state "N₂H_x chemistry has not been well studied compared with other nitrogen chemistry" [25].

Table 5: Details for the NK reactions that could damp the general reactivity without impacting the relative difference between the blends.

#	Reactions	Ref.	Method
6	$\text{NH}_2 + \text{NO} = \text{H}_2\text{O} + \text{N}_2$	[12]	<i>ab Initio</i>
7	$\text{OH} + \text{N}_2\text{H}_4 = \text{NH}_3 + \text{H}_2\text{NO}$	[33]	Experiment
8	$\text{N}_2\text{H}_4 (+ \text{M}) = 2\text{NH}_2 (+ \text{M})$	[15]	Empiric fit
9	$\text{NH}_2 + \text{NO} = \text{OH} + \text{NNH}$	[12]	<i>ab Initio</i>
10	$\text{NH}_2 + \text{H}_2\text{NO} = \text{NH}_3 + \text{HNO}$	[18]	Estimation
11	$\text{HO}_2 + \text{N}_2\text{H}_2 = \text{H}_2\text{O}_2 + \text{NNH}$	[25]	Empiric fit
12	$\text{O}_2 + \text{NH}_2 = \text{OH} + \text{HNO}$	[12]	<i>ab Initio</i>
13	$\text{NH}_2 + \text{NO}_2 = \text{H}_2\text{O} + \text{N}_2\text{O}$	[34]	Empiric fit

4. Conclusions

The ignition delays obtained for ammonia-hydrogen blends prove their suitability for high compression ratio LTC engines (~25:1 for pure ammonia). Such value allows to minimize the intake temperature and consequently the heat losses even though the high compression ratio. Moreover, no ringing has been noticed during these experiments, even at equivalence ratios of 0.5, which ought solely to the long combustion durations observed for ammonia. Three out of the five mechanisms evaluated were found under-reactive for ammonia auto-ignition (DeNO_x-based mechanisms), and two over-reactive (flame-based mechanisms), stressing out the need for an adapted ammonia kinetic mechanism to LTC pressures and temperatures. A sensitivity analysis allowed to identify H₂NO as a possible cause for pure ammonia under-reactivity in the three DeNO_x-based mechanisms, and the N₂H_x chemistry as the cause of the two over-reactive mechanisms. These compounds have been identified and should serve as a first step towards an ammonia-hydrogen LTC mechanism.

With hydrogen addition, fractions higher than 10%vol. were required to induce a significant promotion of the ignition delay. This implies the need for a substantial hydrogen reserve or direct ammonia reformer at the engine intake if promotion is needed.

Finally no significant influence of the equivalence ratio was measured on the ignition delay although a smaller ignition delay is observed both experimentally and numerically at an equivalence ratio of 0.35.

Future work will focus on the improvement of the ammonia mechanisms under LTC conditions through the investigation of the H₂NO and N₂H_x chemistries.

Acknowledgments

This research inscribes in a doctoral grant funded by the FRIA-FNRS (M. Pochet, fellow #17513). The financial support from ENGIE Electrabel and the Investissement d'Avenir Labex Caprysses (ANR-11-LABX-0006-01) is gratefully acknowledged. We also thank the technical team from the PRISME laboratory of Université d'Orléans.

References

- [1] W. L. Ahlgren, Proceedings of the IEEE 100 (2012) 3001–3052.
- [2] P. Van Blarigan, in: 2000 U.S DOE Hydrogen Program Review, San Ramon, California, pp. 639–656.
- [3] M. Pochet, V. Dias, H. Jeanmart, S. Verhelst, F. Contino, Energy Procedia 105 (2017) 1532–1538.
- [4] M. Pochet, I. Truedsson, F. Foucher, H. Jeanmart, F. Contino, SAE Technical Papers. 2017-24-0087 (2017).

- [5] K. J. Lee, Y. R. Kim, C. H. Byun, J. T. Lee, International Journal of Hydrogen Energy 38 (2013) 255–264.
- [6] J. Miller, C. Bowman, Progress in Energy and Combustion Science and Combustion Science 15 (1989) 287–338.
- [7] J. Bian, J. Vandooren, P. J. Van Tiggelen, Proceedings of the Combustion Institute (1990) 379–386.
- [8] R. P. Lindstedt, F. C. Lockwood, M. A. Selim, Combustion Science and Technology 108 (1995) 231–254.
- [9] J. A. Miller, P. Glarborg, International Journal of Chemical Kinetics 31 (1999) 757–765.
- [10] Ø. Skreiberg, P. Kilpinen, P. Glarborg, Combustion and Flame 136 (2004) 501–518.
- [11] P. Dagaut, A. Nicolle, Proceedings of the Combustion Institute 30 (2005) 1211–1218.
- [12] S. J. Klippenstein, L. B. Harding, P. Glarborg, J. A. Miller, Combustion and Flame 158 (2011) 774–789.
- [13] P. Glarborg, A. D. Jensen, J. E. Johnsson, Progress in Energy and Combustion Science 29 (2003) 89–113.
- [14] P. Dagaut, P. Glarborg, M. U. Alzueta, Progress in Energy and Combustion Science 34 (2008) 1–46.
- [15] A. A. Konnov, J. De Ruyck, Combustion Science and Technology 168 (2001) 1–46.
- [16] C. Duynslaegher, F. Contino, J. Vandooren, H. Jeanmart, Combustion and Flame 159 (2012) 2799–2805.
- [17] O. Mathieu, E. L. Petersen, Combustion and Flame 162 (2015) 554–570.
- [18] Y. Song, H. Hashemi, J. Munkholt, C. Zou, P. Marshall, P. Glarborg, Fuel 181 (2016) 358–365.
- [19] N. Bourgeois, S. S. Goldsborough, G. Vanhove, M. Duponcheel, H. Jeanmart, F. Contino, Proceedings of the Combustion Institute 36 (2017) 383–391.
- [20] N. Bourgeois, H. Jeanmart, G. Winckelmans, O. Lamberts, F. Contino, Submitted to Combustion and Flame (2017) Available in the supplementary materials.
- [21] S. S. Goldsborough, S. Hochgreb, G. Vanhove, M. S. Wooldridge, H. J. Curran, C.-J. Sung, Progress in Energy and Combustion Science 63 (2017).
- [22] Y. Zhang, O. Mathieu, E. L. Petersen, G. Bourque, H. J. Curran, Combustion and Flame 182 (2017) 122–141.
- [23] A. Kéromnès, W. K. Metcalfe, K. A. Heufer, N. Donohoe, A. K. Das, C.-j. Sung, J. Herzler, C. Naumann, P. Griebel, O. Mathieu, M. C. Krejci, E. L. Petersen, W. J. Pitz, H. J. Curran 160 (2013) 995–1011.
- [24] J. Li, H. Huang, N. Kobayashi, C. Wang, Energy 126 (2017) 796–809.
- [25] H. Nakamura, S. Hasegawa, T. Tezuka 185 (2017) 16–27.
- [26] S. Gersen, N. B. Anikin, A. V. Mokhov, H. B. Levinsky 33 (2008) 1957–1964.
- [27] A. Cuoci, A. Frassoldati, T. Faravelli, E. Ranzi, Combustion and Flame 160 (2013) 870–886.
- [28] A. Cuoci, A. Frassoldati, T. Faravelli, E. Ranzi, Computer Physics Communications 192 (2015) 237–264.
- [29] A. Dean, J. Bozzelli, in: Gas Phase Combustion Chemistry, Springer, New York, 2000.
- [30] P. Glarborg, K. I. M. Dam-johansen, J. A. Miller, International Journal of Chemical Kinetics 27 (1995) 1207–1220.
- [31] S. Xu, M. C. Lin, International Journal of Chemical Kinetics 41 (2009) 667–677.
- [32] A. M. Mebel, E. W. G. Diau, M. C. Lin, K. Morokuma, Journal of Physical Chemistry 3654 (1996) 7517–7525.
- [33] G. Harris, R. Atkinson, J. J. Pitts, Journal of Physical Chemistry 83 (1979) 2557–2559.
- [34] P. Glarborg, K. I. M. Dam-johansen, J. A. Miller, R. J. Kee, M. E. Coltrin, International Journal of Chemical Kinetics 26 (1994) 421–436.

Appendix

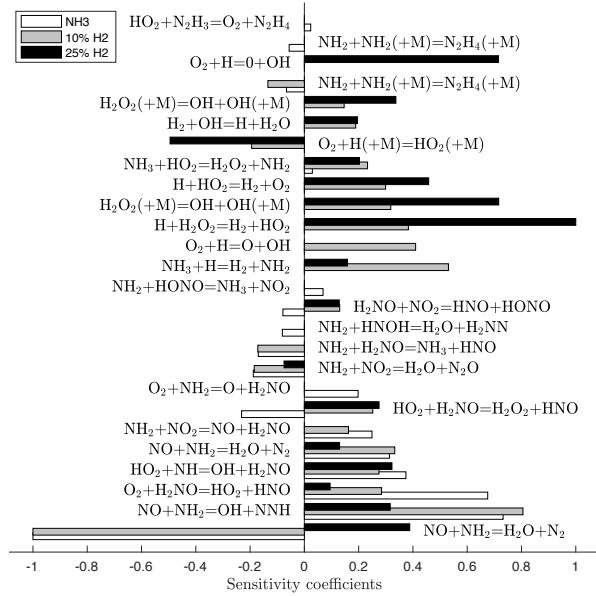

Figure 7: Relative sensitivity coefficients of the SO mechanism sensitivity analysis for mixtures #2,3,4 (at 1075 K, 50 bar).

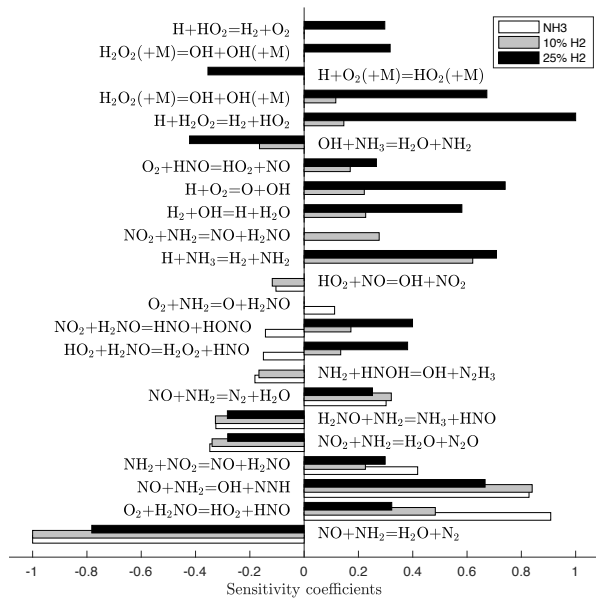

Figure 8: Relative sensitivity coefficients of the ZH mechanism sensitivity analysis for mixtures #2,3,4 (at 1075 K, 50 bar).

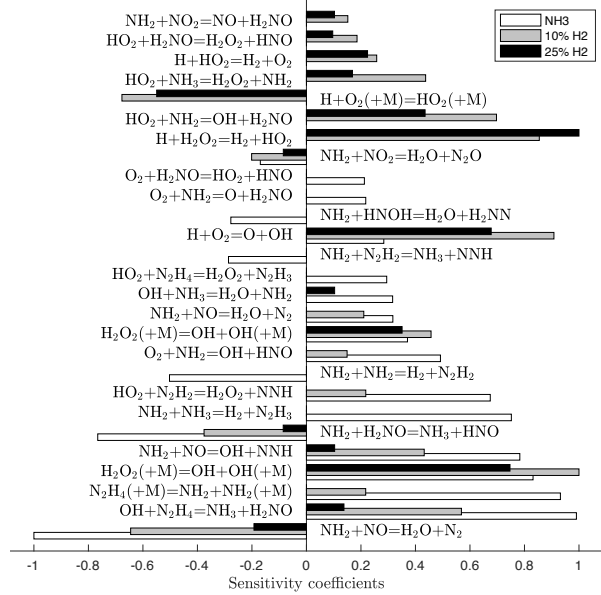

Figure 9: Relative sensitivity coefficients of the NK mechanism sensitivity analysis for mixtures #2,3,4 (at 1075 K, 50 bar).